

**Modular Cooking Range Line
 thermaline 80 - 500 mm Electric Free-
 cooking Top with Smooth Plate, 1 Side
 with Backsplash**

ITEM # _____

MODEL # _____

NAME # _____

SIS # _____

AIA # _____



588323 (MATAABEOAO) Electric Free-Cooking Top, one-side operated with backsplash

Short Form Specification

Item No. _____

Unit constructed according to DIN 18860_2 with 20 mm drop nose top. Internal frame for heavy duty sturdiness in stainless steel. 2 mm top in 1.4301 (AISI 304). Flat surface construction, easily cleanable. THERMODUL connection system enables seamless worktop when units are connected and avoids soil penetrating. Smooth electrically-heated solid plate made of 20 mm thick steel with a wide rounded cleaning zone around the plate. Rapid plate heat up, continuously ready to use; maximum reachable surface temperature of 350°C. Stainless steel high splash guards on the rear and sides. Overheat protection switches off the supply in case of overheating. Standby function saves energy and quickly recovers maximum power. Metal knobs with embedded hygienic silicon "soft" grip enable easier handling and cleaning. IPX5 water resistance certification. Configuration: One-side operated top with backsplash. The base needs to be supplied by the factory. Please include appropriate base.

Main Features

- For direct and indirect cooking.
- Rapid heat up of the plate and continuously ready for use.
- Overheat protection: the temperature sensor switches off the supply in case of overheating.
- Wide rounded cleaning zone around the plates for easier cleaning.
- All major components may be easily accessed from the front.
- THERMODUL connection system creates a seamless work top when units are connected to each other thus avoiding soil penetrating vital components and facilitating the removal of units in case of replacement or service.
- Metal knobs with embedded hygienic "soft-touch" grip for easier handling and cleaning. The special design of the controls prevents infiltration of liquids or soil into vital components.
- Large visible digital display manufactured in tempered glass to resist heat and chemicals, showing temperatures or power settings. The display also shows on/off status of the appliance and on/off status of the heating elements.
- Cooking plate and base joint profile guarantee against soil infiltration.
- Surface temperature up to 350°C

Construction

- Unit constructed according to DIN 18860_2 with 20 mm drop nose top and 70 mm recessed plinth.
- Flat surface construction with minimal hidden areas to easily clean all surfaces
- Internal frame for heavy duty sturdiness in 1.4301 (AISI 304).
- Unit constructed according to DIN 18860_2 with 20 mm drop nose top.
- IPX5 water resistance certification.
- Cooking surface is an electrically heated solid plate made from 20 mm thick stainless steel AISI 316 - DIN 1.4404.
- 2mm thick top in stainless steel AISI 304 - DIN 1.4301.

Sustainability



- Standby function for energy saving and fast recovery of maximum power.

Optional Accessories

- Connecting rail kit for appliances PNC 912497 with backsplash, 800mm
- Portioning shelf, 500mm width PNC 912523

APPROVAL: _____

Front

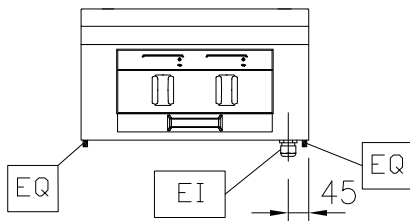

Side

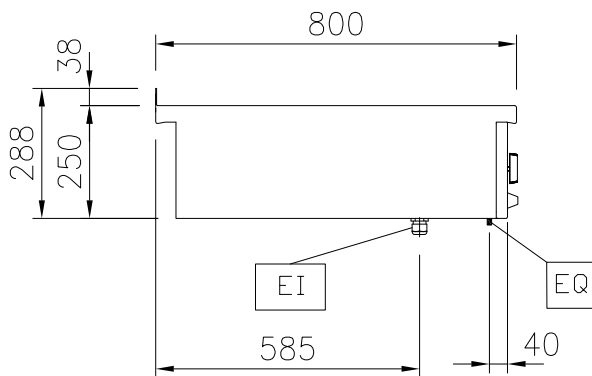

EI = Electrical inlet (power)
 EQ = Equipotential screw

Top

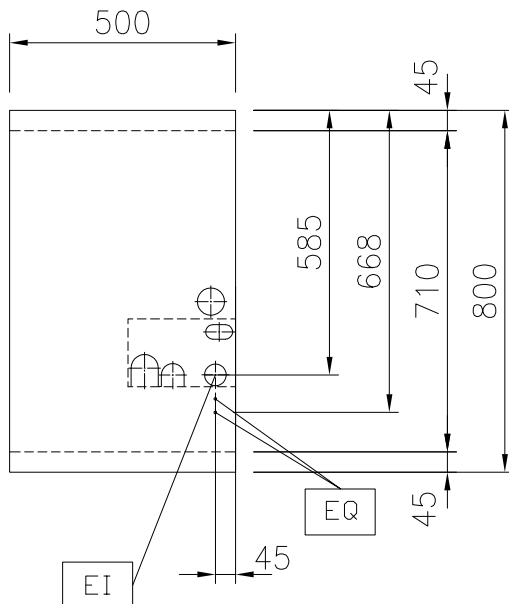
Electric

Supply voltage: 400 V/3N ph/50/60 Hz
 Total Watts: 6 kW

Key Information:

Working Temperature MIN: 80 °C
 Working Temperature MAX: 350 °C
 External dimensions, Width: 500 mm
 External dimensions, Depth: 800 mm
 External dimensions, Height: 250 mm
 Net weight: 70 kg
 Configuration: One-Side Operated;Top

Sustainability

Current consumption: 13 Amps

Optional Accessories

- Connecting rail kit for appliances with backsplash, 800mm PNC 912497
- Portioning shelf, 500mm width PNC 912523
- Portioning shelf, 500mm width PNC 912553
- Folding shelf, 300x800mm PNC 912577
- Folding shelf, 400x800mm PNC 912578
- Fixed side shelf, 200x800mm PNC 912583
- Fixed side shelf, 300x800mm PNC 912584
- Fixed side shelf, 400x800mm PNC 912585
- Connecting rail kit for appliances with backsplash: modular 80 (on the left), ProThermetic tilting (on the right), ProThermetic stationary (on the left) to ProThermetic tilting (on the right) PNC 912977
- Connecting rail kit for appliances with backsplash: modular 80 (on the right), ProThermetic tilting (on the left), ProThermetic stationary (on the right) to ProThermetic tilting (on the left) PNC 912978
- Back panel, 500x700mm, for units with backsplash PNC 913010
- Back panel, 500x800mm, for units with backsplash PNC 913023
- Endrail kit, flush-fitting, with backsplash, left PNC 913113
- Endrail kit, flush-fitting, with backsplash, right PNC 913114
- Scraper for smooth plates PNC 913119
- Endrail kit (12.5mm) for thermaline 80 units with backsplash, left PNC 913204
- Endrail kit (12.5mm) for thermaline 80 units with backsplash, right PNC 913205
- U-clamping rail for back-to-back installations with backsplash (to be ordered as S-code) PNC 913226
- Insert profile D=800mm PNC 913230
- Energy optimizer kit 14A - factory fitted PNC 913244
- Filter W=500mm PNC 913664
- Electric mainswitch 25A 4mm² NM for modular H800 electric units (factory fitted) PNC 913676

Recommended Detergents

- C41 HI-TEMP RAPID DEGREASER, 1 pack of six 1 lt. bottles (trigger incl.) PNC 0S2292